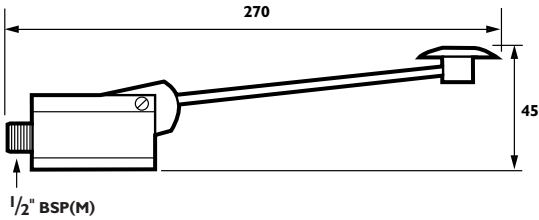

Floor mounted, foot operated**Data**

Pedal operated valve for floor or wall mount.

- Instantaneous automatic shut-off
- Cold or mixed water supply
- Regulated flow-rate 10 L/min under 3 bar
- The pedal can be pulled up to clear the floor
- Fixing by 4 stainless steel screws

Code numbers

736101 - Pedal operated floor mount, 1/2" BSP(M).

736102 - Pedal operated wall mount, 1/2" BSP(M).

Pressures and flow-rates

• Dynamic pressure	bar	0.5	1	2	3	4	5
• Maximum adjustable flow-rate	l/s	0.14	0.20	0.30	0.36	0.40	0.44
• Base flow-rate to calculate water supply pipe:		0.10 l/s					
• Recommended pressure:		0.3 to 5 bar.					

Description

Floor or wall mounted pedal operated controls. They are precision engineered to provide effective control of process water and are easy to use and effective in reducing water use in industrial, food preparation and healthcare environments.

Safe water temperatures.

Basin taps and mixers should always be used in conjunction with an appropriate thermostatic mixing valve to provide a safe maximum water temperature.

Advantages

Vandal resistant: designed for intensive use in public places.

How to specify

Pedal operated control with auto shut off

Floor mounted. Code no. 736101

Wall mounted. Code no. 736102

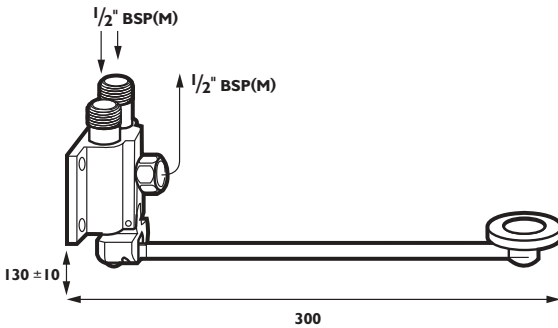
Wall mounted, foot operated

Dimensions in mm