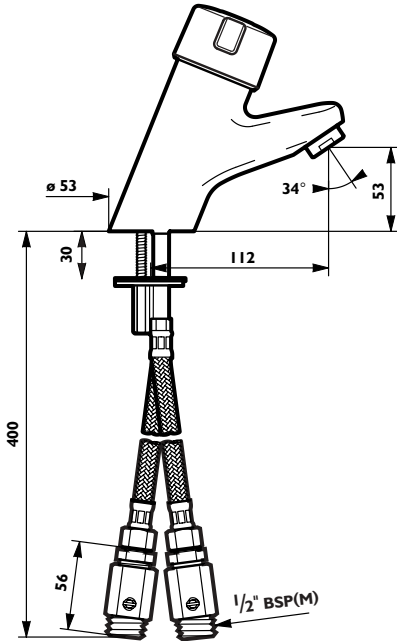

Tempomix basin mixer

Data

Tempomix time flow basin mixer with adjustment of temperature on the control knob.

- Shut-off delay ~20 sec (± 5 secs)
- Stainless steel flexible connectors and non-return valves
- Body in chrome-plated brass, reinforced fixing

Code numbers

795100 - Tempomix with straight stop valves.

Pressures and flow-rates

• Dynamic pressure	bar	0.5	1	2	3	4	5
• Maximum adjustable flow-rate	l/s	0.12	0.16	0.21	0.26	0.32	0.35
• Base flow-rate to calculate water supply pipe:		0.13 l/s = 8 litres/min					
• Recommended pressure:		0.5 to 5 bar.					

Description

Tempomix single control time flow basin mixer with scale-proof aerator.

- Pre-set flow rate 8 L/min, adjustable by the installer without dismantling the mechanism or isolating water supply
- Shut-off delay ~20 sec (± 5 secs)
- Scalding protection: maximum temperature can be limited by the installer
- Stainless steel flexible inlets, filters, non-return check valves and stop valves
- Safe water temperatures
Basin taps and mixers should always be used in conjunction with an appropriate thermostatic mixing valve to provide a safe maximum water temperature.

Advantages

- Vandal resistant: designed for intensive use in public places, fixing reinforced by 2 bolts
- More than 60% water and energy savings. Pre-set flow-rate 8 L/min. and automatic shut-off ~20 sec. delayed
- Comfort: smooth opening, the temperature is user adjustable, progressive adjustment by rotation of the control knob and re-opens at the previous setting

How to specify

Tempomix time flow basin mixer complete with straight stop valves. Code no. 795100

Dimensions in mm